



ORCHID MEDIA SELECTION GUIDE

Orchid Tissue Culture first began with Lewis Knudson aseptically germinating orchid seed in 1922, and this was also a first in successful *in vitro* propagation for any plant (for historical review, Yam and Arditti 2009). PhytoTech Labs offers several media developed for the *in vitro* culture of orchids which range from basic seed sowing media to media for clonal propagation (mericloning) and stem propagation. These media are composed of basic mineral salts, which must be supplemented with other components, as well as media that are complete and require only the addition of water and sterilization. Each medium is tested based on physiochemical specifications, and then biologically tested with two commercially significant orchid or other plant cell lines.

MS (Murashige & Skoog 1962) basal media with vitamins (e.g. M519, M404) used at 1X and 1/2X and supplemented with plant growth regulators is frequently used for various micropropagation stages of different orchid species (Chugh *et al.* 2009, Teixeira da Silva *et al.* 2015). The basal nutrients of more complex Orchid Media are often based on 1/2X MS media (e.g. O156, P668) and even 1/4X MS (e.g. P723) for salt-sensitive species. Other unique basal media have been developed for North American (Harvais 1982, Malmgren 1996) and Western European (Van Waes and Debergh 1986) terrestrial orchids or used to germinate Central American epiphytes (Vacin and Went 1949). Due to the salt-sensitivity of some Orchid species, it is important to distinguish the ion concentrations across these media (See Table 1 below).

TABLE 1. Ion Concentrations of Orchid Tissue Culture Media

Ion	Ion Concentration [mM]						
	Knudson's C (1946) - K400	Vacin & Went (1949) - V505	1/2X MS-based (e.g. P668, O156)	1/4X MS-based (e.g. P723)	Terrestrial Medium (Harvais 1982) - T849	Basic Medium (BM) (Van Waes & Debergh 1986) - B138	Malmgren's (1996) - M482
NH ₄ ⁺	13.81	7.57	10.31	5.15	17.88	-	-
NO ₃ ⁻	10.48	5.19	19.70	9.85	24.34	-	-
K ⁺	5.19	7.03	10.02	5.01	4.79	2.20	0.55
Ca ²⁺	2.12	1.99	1.50	0.75	2.44	-	0.75
Mg ²⁺	1.01	1.01	0.75	0.38	0.81	0.83	0.81
PO ₄ ³⁻	1.84	3.03	0.62	0.31	1.47	2.20	1.00
SO ₄ ²⁻	4.92	4.93	0.92	0.46	0.82	1.11	0.92
Cl ⁻	3.35	-	2.99	1.50	1.34	1.05E-04	-
B	-	-	0.05	0.03	0.01	0.16	-
Co ²⁺	-	-	5.25E-05	2.63E-05	-	1.05E-04	-
Cu ²⁺	-	-	5.01E-05	2.50E-05	1.00E-04	1.00E-04	-
Citrate	-	-	-	-	0.17	-	-
EDTA	-	0.10	0.10	0.05	-	0.10	0.10
Fe ³⁺	0.09	0.10	0.10	0.05	0.04	0.10	0.10
I ⁻	-	-	2.51E-03	1.26E-03	6.02E-04	-	-
Mn ²⁺	0.03	0.03	0.05	0.02	0.01	0.15	0.01
Mo ²⁺	-	-	5.17E-04	2.58E-04	8.27E-05	1.03E-03	-
Na ⁺	-	0.20	0.10	0.05	1.65E-04	0.20	0.20
Zn ²⁺	-	-	0.01	0.01	1.74E-03	0.03	-

Carbohydrates are usually incorporated into orchid media via sucrose (Prod. No. S391, S829) at 20 g/L, and to a lesser extent as glucose (Prod. No. G360, G386). Sorbitol (Prod. No. S744) and Mannitol (Prod. No. M462) are a class of carbohydrates known as sugar alcohols, but they must be metabolized in the plant to become available as a carbon source (Loescher 1987). They are storage forms of carbohydrates generated during photosynthesis, but they are used more in tissue culture as enhancers of osmolality. Mannitol has shown benefits in germination of *Bletia purpurea* germination when combined with sucrose and fructose (Johnson and Kane 2013).

Many orchid media contain complex organic additives such as peptone, casein, banana powder, as well supplemented coconut to support growth. In 1941, van Overbeek *et al.* first established coconut water as an organic supplement to *Datura* culture media, and since then it has been used often in orchid tissue culture. Coconut water contains various nutrients that contribute to tissue growth, particularly sugars, lipids, vitamins, and amino acids (Van Staden and Drewes 1975; Yong *et al.* 2009). Coconut milk and coconut powder have also been used as a supplement. While some studies use the terminology of coconut milk and water interchangeably, the difference is coconut water is the clear liquid found inside while coconut milk refers to the mixture made from the white flesh of the coconut and mainly consists of fat. Coconut powder is a dried form of the flesh of the coconut (Arditti and Ernst, 1993).

Ripened banana pulp has a long history in orchid micropropagation, but the short shelf-life makes it unfeasible to be commercial produced. Banana powder (Prod. No. B852) is a consistent dry powder form of homogenized banana puree, and it has been used with 'Slipper' orchids (*Paphiopedilum* sp.) (Ernst 1974). Banana additives may interfere with germination, and it is used more in replante media (Arditti 1982)

Peptone is usually considered just as a carbon and nitrogen source, but the primary source of these nutrients come from polypeptides, amino acids, organic acids and nitrogen bases, as well as carbohydrates. Peptone from bovine meat extract, digested with porcine enzymes have primarily been used over soy extracts based on higher total nitrogen and amino nitrogen contents. Peptone has also enhanced somatic embryogenesis in *Oncidium* (Chen and Chang 2002). Casein hydrolysate is bovine milk hydrolyzed with porcine enzymes, and the amino acid profile is like animal-derived peptone.

Benzyladenine (BA, 6-BA, or BAP) is one of the most widely used cytokinin's and α -Naphthaleneacetic Acid (NAA) is the most used auxin for orchid tissue culture. Shoot tip culture is normally performed with only cytokinin. For more information on cytokinins see Sakakibara (2006), and for roles in root initiation: Blakesley *et al.* (1991).

Activated charcoal (AC, Prod. No. C325) is primarily used to bind phenolics exuded from tissue during growth but are also known to aid rooting (Pan and van Staden 1998). Phenolics result from plant allelopathy and can be phytotoxic in culture. Some of these phenolic compounds have been identified (Li *et al.* 2010). There are a variety of sources for AC, but ours comes from charred coconut husks. AC is typically used at concentrations of 0.1-2.0 g/L. Polyvinylpyrrolidone (PVP-40, Prod. No. P728) is also used to bind phenolics.

It should be noted that many plant growth regulators (PGRs) are aromatic compounds (e.g. BA, NAA, kinetin, etc.) and can bind to AC in tissue culture media (Thomas 2008). It is generally not recommended to add PGRs to complex media with AC; PGRs are more efficiently used with basal media like MS. Product numbers O753, M507, and P793 are more complex orchid-specific media that contain PGRs without activated charcoal. It is possible to overcome this binding of PGRs to AC (Van Winkle and Pullman 2005), but this should be empirically determined on a medium-by-medium basis.

The following tables (2 & 3) are intended to provide a starting point in selecting the proper media for your orchid species. These media have been reported in the literature to work with these species or have been recommended to us from growers.

TERRESTRIAL ORCHID MEDIA SELECTION GUIDE

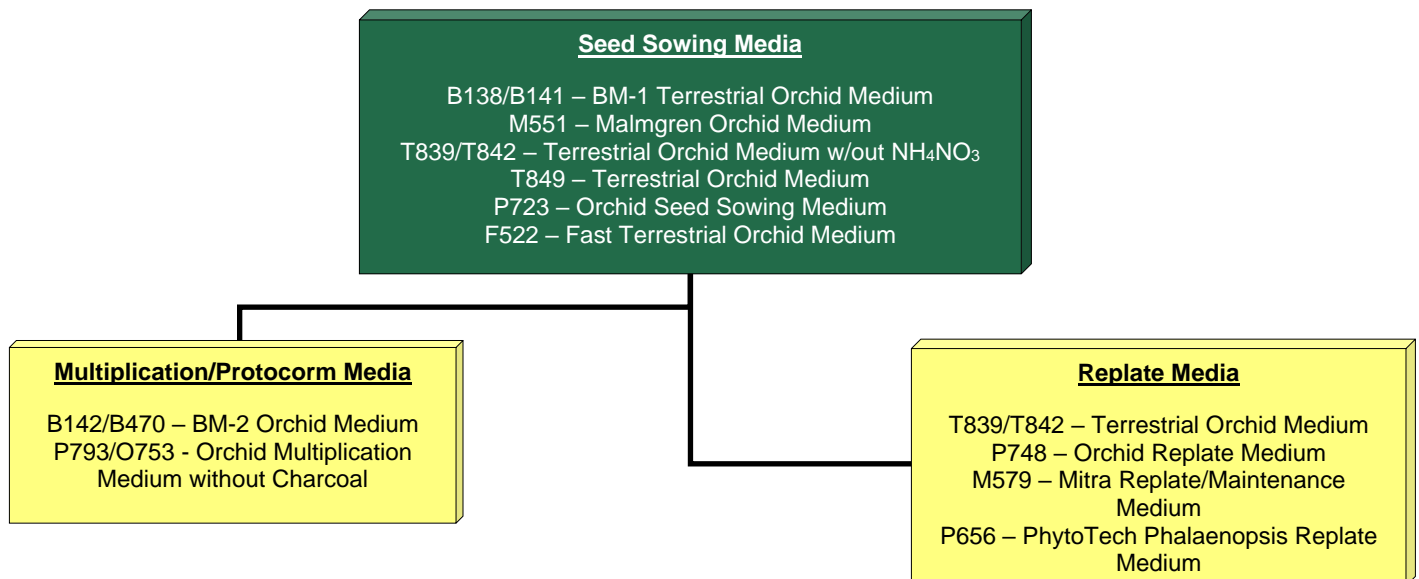

PhytoTech Labs Inc.

Phone: 888-749-8682 or 1-913-341-5343

phytotechlab.com

Table 2. Terrestrial Orchid Media Selection by Genus

Genus	Germination Medium/Media	Replate Medium/Media	Multiplication/Protocorm forming Media
<i>Aplectrum</i>	K400	K400, K425	
<i>Arethusa</i>	K400, P723	K400, K425, P748	
<i>Bletia</i>	B138/B141, K400, P723, V895	P748, V895	
<i>Bletilla</i>	P668 ¹ , P723, N5954	P668, P748	P793, O753
<i>Calopogon</i>	B138/B141, K400, P723	P723, P748	
<i>Calypso</i>	B138/B141, B142/B470, F522	F522	
<i>Coeloglossum</i>	K400	K400, K425, P748	
<i>Cymbidium</i>	M579 ⁴ , P668, P793 ⁴	M579	P793, O753
<i>Cypripedium</i>	B142/B470 ² , F522, K400 ^{1,2} , M551 ³ , T839 ² , T842 ² , T849 ² , T8133 ²	B138/B141, F522, K400 ^{1,2} , P668 ¹ , T849	P793, O753
<i>Dactylorhiza</i>	B138/B141, F522	F522, P748	
<i>Epipactis</i>	B142/B470	B138/B141, P668	
<i>Eulophia</i>	P723, V895	P748, V895	
<i>Goodyera</i>	M551, P668 ¹ , P723	P748	
<i>Gymnadenia</i>	B138/B141, F522, M551, P668 ¹	F522, M551, P748	
<i>Limodorum</i>	B142	B142	
<i>Liparis</i>	K400	K400, K425, P748	
<i>Oeceoclades</i>	P668 ¹ , P723, V895	P723, V895	
<i>Ophrys</i>	M551	M551	
<i>Orchis</i>	B138/B141, F522, M551, P668 ¹	F552, M551	
<i>Paphiopedilum</i>	P668 ^{1,2}	P668 ¹ , P668	
<i>Phragmipedium</i>	P668 ^{1,2}	P668 ¹ , P668	
<i>Platanthera</i>	B138/B141, F522, K400, L472, M551, P668 ¹ , P723	F552, M551, P723, P748	
<i>Pogonia</i>	K400	K400	
<i>Habenaria</i>	M551, P723	M551, P748	
<i>Sacoila</i>	K400, M551		
<i>Spathoglottis</i>	P723	P668, P723, P748	P793, O753, B138/B141 ²
<i>Spiranthes</i>	K400, M551, P723	M551, P748	P793, O753
<i>Thelymitra</i>	B138/B141, P723, T839, T842	P748, T839, T842, T849	
<i>Tipularia</i>	K400	K400, K425	
<i>Zeuxine</i>	P723	P723, P748	

¹Medium used at 1/2-strength.

²Medium supplemented with up to 15% coconut water (Product C195).

³Medium supplemented with either 10 g/L sucrose (Product S391) or 5 g/L S391 + 5 g/L glucose (Product G360).

⁴Medium supplemented with 2 g/L peptone (Product P775) many enhance germination of some spp.

Please see “Media Recommendation Note” at end of this publication for additional information.

PhytoTech Labs Inc.

Phone: 888-749-8682 or 1-913-341-5343

phytotechlab.com

EPIPHYTIC ORCHID MEDIA SELECTION GUIDE

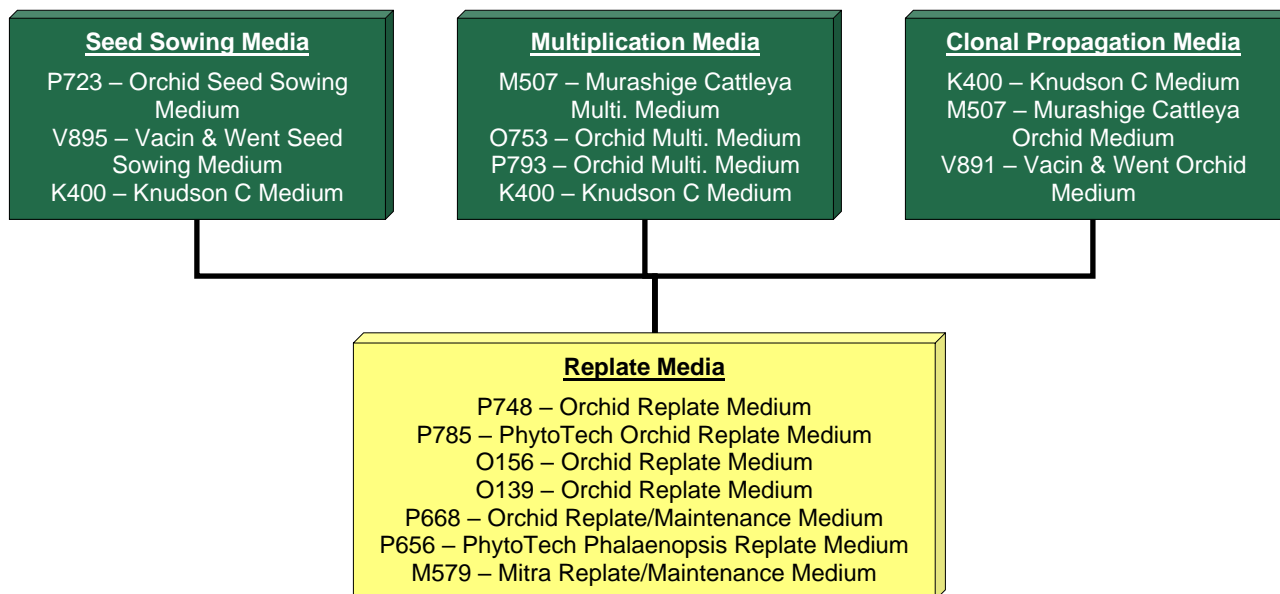

Table 3. Epiphytic Orchid Media Selection by Genus

Genus	Germination Medium/Media	Replate Medium/Media	Multiplication/Protocorm forming Media
<i>Ascocenda</i>	K400, P668 ¹ , P723, P785, V895	O156, P668	M507
<i>Brassia</i>	K400, K425, P723	K425, P748	O753, P793
<i>Cattleya</i>	K400, K425, L472, P668 ¹ , P723, P785, V895	K400, K425, O156 ¹ , P668 ¹ , P748, P785	M507, O753, P793
<i>Cyrtopodium</i>	P723, K400, V895	P723, P748	
<i>Dendrobium</i>	P668, K400, K425, M579, V895, C167	K400, K425, M579, V895	M507, O753, P793
<i>Dendrophylax</i>	P723	P723, P748	
<i>Encyclia</i>	P723, P748	P748	
<i>Epidendrum</i>	K400, K425, M579, P668 ¹ , P723, V895	K400, K425, O156, P668, P748, P785, V895	
<i>Gongora</i>	K425, P723	K425, P748	
<i>Maxillaria</i>	P723	P748	
<i>Oncidium</i>	P668 ¹ , P723	O156 ¹ , P668 ¹ , P723, P748	M507, O753, P793
<i>Odontoglossum</i>	K400, K425, P723	K400, K425, O156 ¹	
<i>Phalaenopsis</i>	I365, K400, P656, P668 ¹ , P723, P785	I365, O156, P656, P668, P748, P785	M507, O753, P793, N5954
<i>Pleurothallis</i>	P668, P668 ¹ , P723	O156, O156 ¹ , P748	
<i>Prosthechea</i>	P723	P723, P748	
<i>Schomburgkia</i>	P723	P723, P748	
<i>Vanda</i>	K400, M579, P723, P785, V895	M579, O156, P723, P748, V895	
<i>Vanilla</i>	K400, K425	K400, K425, V895	

¹Medium used at 1/2-strength.

PhytoTech Labs Orchid Media Family Relations

The following table provides information on how the orchid media in each "family" is related to each other. This guide provides a basic look at how one medium is different from another. In many cases one medium become equivalent to another with one supplement. If you **Start With** one medium and make the **Addition or Change** as described it **Creates** the medium listed.

BM Family (BM-1, BM-2)

Start With	Addition or Change	Creates	Application
B138	plus Agar	B141	Developed for seed germination, replate, & multiplication of terrestrial orchids.
B141	plus BA	B142	
B138	plus BA	B470	

Malmgren Family

Start With	Addition or Change	Creates	Application
M482	plus Pineapple Powder	M534	Developed for hardy terrestrial orchids (<i>Cypripedium</i> in particular).
M534	plus Agar	M551	

Maintenance/Replate Family

Start With	Addition or Change	Creates	Application
O6339	plus Sucrose & Peptone	O139	Suitable for replating most epiphytic & terrestrial orchids.
O139	plus Charcoal	P668	
P668	plus Agar	P658	
P668	plus Banana Powder	O156	
O156	plus Agar	P748	

Seed Sowing Family

Start With	Addition or Change	Creates	Application
P727	plus Charcoal	P723	Suitable for germinating most epiphytic & terrestrial orchids.

Slipper Orchid Family

Start With	Addition or Change	Creates	Application
T8133	plus Agar	T842	Suitable for seed germination & replate of slipper orchids
T842	double Casein	T839	
T842 & T839	minus Casein; plus Ammonium Nitrate	T849	

Vacin & Went Family

Start With	Addition or Change	Creates	Application
V505	plus Thiamine HCl	V882	Developed for general use in seed germination, replate, & multiplication of most epiphytic orchids.
V882	plus Sucrose	V891	
V891	plus Agar	V895	

Multiplication Family

Start With	Addition or Change	Creates	Application
P793	plus Agar	O753	Suitable for the multiplication of most epiphytic & terrestrial orchids.

Proprietary Replate/Seed Sowing Family

Start With	Addition or Change	Creates	Application
P781	plus Banana Powder & Gelling Agent	P785	Suitable for germinating most epiphytic & terrestrial orchids.

Proprietary Replate/Seed Sowing Family

Product No.	Major Components	Application
K425	Contains Charcoal, Sucrose, Banana Powder, & Gelling Agent	Suitable alternative to K400 for seed germination & replate.
P656	Contains Charcoal, Sucrose, Banana Powder, Potato Powder, & Gelling Agent	Developed for <i>Phalaenopsis</i> seed germination, replate, & tissue culture.

Continued next page

Unique Formulations

Product No.	Application
F522	Developed for the seed germination & replate of terrestrial orchids, particularly <i>Cypripedium</i> and <i>Calypso</i> .
I365	Originally developed for <i>Phalaenopsis</i> seed germination, replate, & tissue culture.
K400	Original & classic seed germination & replate medium.
L472	Developed as an alternative to K400 for seed germination & tissue culture.
M507	Developed for the culture & multiplication of <i>Cattleya</i> & allies.
M579	Developed for the seed germination & replate of <i>Vanda</i> & allies.

ORCHID SEED GERMINATION

Orchid seeds are very small and contain little food reserves. Some orchid seeds may require stratification (cold treatment at 4°C) for months or be dried at -10°C. For an overview of techniques and applications in germination, see Kauth *et al.* 2008. A single seed capsule may contain 1,500 to 3,000,000 seeds. Sowing the seed *in vitro* makes it possible to germinate immature seed (green pods). It is usually easier to sterilize the green capsule than individual seed after the capsule has dehisced. Lucke (1971) indicated that orchid seed can be sterilized when the capsule is about two-thirds ripe. Listed below are approximate normal ripening times of capsules for various orchid species. Exact capsule ripening times may vary depending on species, hybrid, and growing conditions. It has been observed that darker colored orchid seeds may lighten in color during the bleaching for seed sterilization and this can improve germination (Steele, 1996). Though calcium hypochlorite has been used often in orchid seed protocols, its potency and stability even in dry crystal/powder form make sodium hypochlorite a more consistent disinfectant.

ORCHID GENERA	TIME TO MATURITY (MONTHS)	ORCHID GENERA	TIME TO MATURITY (MONTHS)
Bletilla	3	Laelia	9
Bulbophyllum	3	Masdevallia	3.5
Brassia	9	Miltonia	9
Calanthe	4	Odontoglossum	7
Catasetum	10	Oncidium	9
Cattleya	11	Paphiopedilum	10
Coelogyne	13	Phaius	7.5
Cymbidium	5-10	Phalaenopsis	6
Cypripedium	3.5	Spathoglottis	1.5
Dendrobium	12	Stanhopea	7
Encyclia	8	Vanda	9
Epidendrum	3.5		

Immature (Green) Capsule Disinfection

1. Soak the immature (green) seed capsule in 100% commercial bleach (6% sodium hypochlorite) for 30 minutes.
2. Dip the capsule in ethanol (70-95%) for 5-10 seconds. Remove the capsule from the alcohol and carefully flame off the excess alcohol.
3. Under aseptic conditions, using a sterile knife or scalpel, open the capsule and scrape out the seed.
4. Carefully layer the seed over the surface of the culture medium. Seal all culture vessels. These vessels are now your mother flasks.

Mature (Dry) Seed Disinfection

1. Collect seed and place in a small container.
2. Prepare a solution containing 5-10% commercial bleach (0.3-0.6% sodium hypochlorite) containing a few drops (2 drops/50 mL) of Tween 20 (Prod. No. P720).
3. Add the bleach solution to the container and swirl the container periodically for 5-10 minutes.
4. Under aseptic conditions, pour off the bleach solution and rinse the seed with sterile tissue culture grade water (Prod. No. W783) 4-5 times with the equivalent volume used for the disinfectant solution.
5. Transfer the seed to sterile culture medium and seal all culture vessels. These vessels are now your mother flasks.

PhytoTech Labs Inc.

Phone: 888-749-8682 or 1-913-341-5343

phytotechlab.com

Replanting Seedlings

1. It may take anywhere from 1 month up to 9 months for the seed to begin to germinate. Approximately 30 to 60 days after germination begins, it will be necessary to transfer the seedlings to fresh medium for continued growth.
2. Prepare an orchid maintenance/ replate medium, such as P748 for epiphytic orchids or T849 for terrestrial orchids.
3. Under aseptic conditions, transfer the seedling from the mother flask to the flask containing the fresh medium. You should place the seedling about ¼" apart on the medium.
4. Allow the seedlings to continue to grow and develop. Root formation generally begins when the plant has 2-3 leaves. Continue to transfer the seedlings to fresh media every 30-60 days, increasing the spacing between the plants with each transfer. When the flask is ready for transfer to a community pot in the greenhouse, most flasks should have 15 to 25 plants depending upon the species.
5. Transfer the plants into a community pot using a finely ground orchid mix.

ORCHID STEM PROPAGATION METHODS

One of the oldest propagation methods for orchids is by lateral buds on floral spikes, or more generally referred to as stem propagation. Below is a method that compiles different strategies from literature and our experience.

1. Remove any flowers that may remain on the stalk. Use clean, healthy, vigorous flower stalks with buds in their nodes. Stalks on which only a few flowers have bloomed are best. Avoid old flower stalks.
2. Wash the flower stalk under running tap water for 5 minutes. Ethanol (70-95%) can also be used to immerse the tissue for very short times (<2 min), or to wipe with gauze (Tanaka and Sakanishi 1978)
3. Prepare a 10% commercial bleach (e.g., Clorox®) solution in distilled/deionized water and 0.1% (w/w) Tween® 20 (Product No. P720) to this solution. The concentration of this solution and duration of the disinfection are highly dependent on the population and types of micro-organisms the plant has on the surface, and what the tissue can survive.
4. Section the stalk with a clean razor blade or scalpel and cut between the nodes. Cut the flower stalk into approximately 1.5 – 3.0 cm sections leaving at least 0.7 cm below the node and the remainder above the node.
5. Disinfect the nodal sections in the bleach solution (from Step 3) for 10-15 minutes. 50 mL centrifuge tubes work well for a few pieces of tissue. Swirl the solution or invert the 50 mL tube every 2-3 minutes. Laboratory rocking platforms, 'belly dancers', or shakers at low speeds can be useful in this step.
6. Pour off the bleach solution and rinse the nodes with sterile distilled/deionized water. Use the equivalent volume of the bleach solution for sterile water rinses. Add sterile water, swirl/invert, then pour off the water. Repeat this step a minimum of 3 times. We often use 4-5 times to rinse as residual hypochlorite from bleach is phytotoxic.
7. Under aseptic conditions, carefully remove the bract from around the node with forceps. All tools should be immersed in a glass bead sterilizer for at least 2 seconds in between every contact with tissue. Tools also need to be able to cool before proceeding.
8. Depending on the number of microorganisms on the surface of the tissue, continued disinfection with sterile water rinses, may be necessary.
9. This optional step helps to remove tissue damaged from the disinfection. The need for this step can often be seen through a browning of the tissue. Remove approximately 0.3 cm from each end of the nodal sections using a clean, sterile scalpel or razor. Also, immersing in an antioxidant solution (Prod. No. A126) immediately before the next step can limit further oxidation and browning of the tissue.
10. Transfer the nodal section to the culture vessels containing Orchid Multiplication Medium (Product No. O753). A variety of additives like Insert the longer portion of the nodal section into the medium at a slight angle to just below the bud. This should result in the emerging shoot pointing upwards.
11. Most shoots will generally appear within 30 days, and they are ready for replating after about 60 days. Some nodes exude phenolic compounds into media and need to be replated on new media or sections that have not turned color.
12. After 30-60 days, replate onto Orchid Maintenance Medium (Product No. P748) and allow the plantlets to continue to develop and root. Roots will begin to appear after 2 or 3 leaves have been produced.

PhytoTech Labs Inc.

Phone: 888-749-8682 or 1-913-341-5343

phytotechlab.com

PROTOCOLMICROPROPAGATION METHODS

In nature, orchids generally require symbiotic fungi to fully develop. In Plant Tissue Culture, orchids can undergo asexual propagation that produces clonal bodies which can then develop into mature adult plants. These clonal bodies are called protocorm-like bodies (PLBs), and there is cytological evidence they are very similar to somatic embryos (Lee et al. 2013). Leaf segments (Park et al. 2002) and callus (Ng and Saleh 2011) are typical starting materials and cytokinin's (e.g., BA, kinetin) are used to induce these tissue types into PLBs. Below is a method based on Paek et al. (2011) using leaf segments.

1. In an aseptic environment, transversely cut leaves into 1.0 x 0.5 cm sections from an existing plant in culture, prioritizing using the youngest leaves.
2. Soak sections for 2 hr in liquid 1/2XMS medium supplemented with 30 g/L sucrose, BA (Prod. No. B130) at 2-3 mg/L. Peptone (Prod. No. P775) or Casein Hydrolysate (Prod. No. C184) can also be added at 2 g/L. Also coconut water (Prod. No. C195) can be added at 10% (w/w).
3. Place leaf segments (lower side, or bottom) down flat on medium in dark for 1 week at 27°C. Section 2 mentions a medium that could be used with 8 g/L of agar added (Prod. No. A111 or A296). 25 segments per 30 mL of media in petri-dishes.
4. Transfer to growth room at 25°C with a 16 hr photoperiod (20 $\mu\text{mol}/(\text{m}^2\cdot\text{s})$) for 6 weeks.
5. Subculture using the upper portion of the induced PLBs and discard the lower portion.

KEIKI PASTE USE

Keikis are vegetative (asexual) offshoots of a cultivated orchid. These keikis can quickly mature after separation from the parent orchid. Typically, keikis are used to cultivate flowering plants and therefore are not kept for *in vitro* micropropagation. Keiki paste (Prod. No. K424) contains hormones and vitamins that can induce vegetative development of a floral node (Batchelor 1981).

ORCHID MEDIA PREPARATION INSTRUCTIONS

Powdered media are extremely hygroscopic and must be protected from atmospheric moisture. If possible, the entire contents of each package should be used immediately after opening. Media stored at 2-8°C and tightly sealed should last 2-3 years, depending on how often and for how long the medium bottle is open. Preparing the medium in a concentrated form is not recommended as some salts in the medium may precipitate. The basic steps for preparing the culture medium:

1. Measure out approximately 70% of the required final volume of tissue culture grade water (Product No. W783), or deionized or distilled water e.g., 700 ml for a final volume of 1000 ml. Select a container twice the size of the final volume. Add a magnetic stir bar (e.g. Prod. No. B012), and place on a stir-plate.
2. While stirring the water, add the powdered medium and stir until completely dissolved. Media containing charcoal, fruit extracts, and/or agar will not completely dissolve.
3. Rinse the container that the medium was packaged in with a small volume of tissue culture grade water to remove traces of the powder. Add to the solution in Step 2.
4. Add desired heat stable supplements (e.g., sucrose, gelling agent, vitamins, cytokinins, etc.). (**Orchid media B142, B141, M551, P723, P748, P785, O753, T849, V895, F522, M579, and P656 are complete media and generally do not require the addition of any other components.**)
5. Add additional tissue culture grade water (Prod. No. W783 or deionized or distilled) to bring the medium to the final volume.
6. While stirring, determine and adjust, if necessary, the medium to desired pH using NaOH, HCl, or KOH. A pH of 5.3 to 5.4 is recommended for many orchid media. For small labs or home hobbyists, pH can be adjusted by using baking soda to raise the pH and vinegar to lower the pH of the medium.
7. Sterilize the medium in a validated autoclave at 1 kg/cm² (15 psi), 121°C, for the time period described under the section titled "Sterilization of Media".
8. Place medium on stir-plate for a minimum of 5 minutes.
9. Add heat labile components, aseptically after autoclaving when the medium has cooled to ~50°C.
10. Dispense the medium into the culture vessels before (or after) autoclaving according to your application.
11. Allow medium to cool and solidify for at least 3-4 hrs prior to use.

PhytoTech Labs Inc.

Phone: 888-749-8682 or 1-913-341-5343

phytotechlab.com

STERILIZATION OF MEDIA

Plant tissue culture media are generally sterilized by autoclaving at 121°C and 1 kg/cm² (15 psi). Media can be sterilized in either an autoclave or pressure cooker with similar results. Recently, the use of the microwave oven has been reportedly used to sterilize media. However, well controlled studies are few; results from a clinical microbiology study indicated that while microwave “sterilization” may be useful in decontaminating contaminated cultures, it is not recommended for the sterilization of fresh medium (Latimer & Matsen, 1977). The time required for autoclave sterilization depends upon the volume of medium in the vessel. The minimum time required for sterilization of different volumes of medium are listed below. NOTE: Instruments such as forceps and scalpels should be autoclave for a minimum of 15 min.

MINIMUM STERILIZATION TIME FOR PLANT TISSUE CULTURE MEDIA

Volume of Medium per Vessel [mL]	Minimum Autoclaving Time ^a [min]
250	31
500	35
1000	40
2000	48
4000	63

^a **Minimum Autoclaving Time** includes the time required for the liquid volume to reach the sterilizing temperature (121° C) and 15 min at 121°C (Burger, 1988). Times may vary due to differences in autoclaves. Validation with your autoclave or pressure cooker is recommended.

PhytoTech Labs Inc.

Phone: 888-749-8682 or 1-913-341-5343

phytotechlab.com

REFERENCES:

- Alam MF Sinha P, and ML Hakim (2010) Micropropagation of *Vanda teres* (Roxb.) Lindle. In: Protocols for In Vitro Propagation of Ornamental Plants. Eds. SM Jain and SJ Ochatt. Methods In Molecular Biology. Humana Press. New York.
- Arditti J (1982) *Orchid Biology: Reviews and Perspectives, II*. Cornell University Press. Ithaca, New York.
- Arditti J, Ernst R. (1993) Micropropagation of orchids. New York: Wiley Interscience. New York
- Batchelor SR (1981) Orchid Culture — 12 — Propagation on a Small Scale. *Am. Orchid Soc. Bull.* 51(2):137-144
- Blakesley D, Weston GD, and JF Hall (1991) The role of endogenous auxin in root initiation. *Plant Growth Regul* 10:341–353 (1991)
- Burger DW (1988). Guidelines for autoclaving liquid media used in plant tissue culture. *HortSci.* 23(6):1066-1068.
- Chen JT and Chang WC (2002) Effects of tissue culture conditions and explant characteristics on direct somatic embryogenesis in *Oncidium 'Gower Ramsey'*. *Plant Cell Tissue and Organ Culture.* 69:41-44
- Chugh S, Guha S, and IU Rao (2009) Micropropagation of orchids: A review on the potential of different explants. *Sci. Hortic.* 122:507–520
- Ernst R (1974) The use of activated charcoal in asymbiotic seedling culture of *Paphiopedilum*. *Am. Orchid Soc. Bull.* 43:35-38
- Harvais G (1982) An improved culture medium for growing the orchid *Cypripedium reginae* axenically. *Can. J. Bot.* 60(12):2547-2555
- Johnson TR and ME Kane (2013) Differential germination and developmental responses of *Bletia purpurea* (Orchidaceae) to mannitol and sorbitol in the presence of sucrose and fructose. *J Plant Nutrition* 36(5):702-716
- Kauth PJ, Dutra D, Johnson TR, Stewart SL, Kane ME, and W Vendrame (2008) Techniques and applications of in vitro orchid seed germination. In: *Floriculture, Ornamental and Plant Biotechnology: Advances and Topical Issues, Volume V*. Chapter:38: Global Science Books.
- Knudson L (1922) Nonsymbiotic germination of orchid seed. *The Botanical Gazette.* LXXIII(1):1-25
- Knudson L (1946) A new nutrient solution for the germination of orchid seed. *American Orchid Society Bulletin* 15(5): 214–217.
- Latimer JM and JM Matsen (1977) Microwave Oven Irradiation as a Method for Bacterial Decontamination in a Clinical Microbiology Laboratory. *J Clinical Microbiol.* 340-342.
- Lee YI, Hsu ST, and EC Yeung (2013) Orchid protocorm-like bodies are somatic embryos. *Am. J. Bot.* 100(11):2121-2131.
- Li ZH, Wang Q, Ruan X, Pan CD, and DA Jiang (2010) Phenolics and Plant Allelopathy. *Molecules.* 15:8933-8952
- Loescher WH (1987) Physiology and metabolism of sugar alcohols in higher plants. *Physiol. Plant.* 70:553-557.
- Lucke E (1971) Zur Samenkeimung Mediterraener Ophrys. *Die Orchidee* 22:62-65.
- Malmgren S (1996) In: C. Allen, Editor, North American Native Terrestrial Orchids. Propagation and Production Conf. Proc., pp 63-71.
- Ng CY and NM Saleh (2011) In vitro propagation of *Paphiopedilum* orchid through formation of protocorm-like bodies. *Plant Cell Tiss Organ Cult.* 105:193-202.
- Paek et al. (2011) Micropropagation of *Phalaenopsis* Orchids via Protocorms and Protocorm-Like Bodies. In: *Plant Embryo Culture: Methods and Protocols*. Methods in Molecular Biology, vol. 710: 293-306. Springer. Clifton, NJ USA
- Pan MJ and J van Staden (1998) The use of charcoal in in vitro culture – A review. *Plant Growth Regulation* 26:155-163
- Park SY, HN Murthy, and KY Paek (2002) Rapid propagation of *Phalaenopsis* from floral stalk-derived leaves. *In Vitro Cell Dev. Biol. – Plant* 38:168-172
- Sakakibara H. Cytokinins: activity, biosynthesis, and translocation. *Annu Rev Plant Physiol Plant Mol Biol.* 2006;57:431–449
- Steele, WK. (1996). Large Scale Seedling Production of North American *Cypripedium* Species. In: C. Allen, Editor, North American Native Terrestrial Orchids. Propagation and Production Conf. Proc., May 16 & 17, 1996. pp 11-26.
- Tanaka M and Y Sakanishi (1978) Factors affecting the growth of *in vitro* cultured lateral buds from *Phalaenopsis* flower stalks. *Scientia Hort.* 8:169-178.
- Teixeira da Silva JA, Cardoso JC, Dobránszki J, and S Zeng (2015) *Dendrobium* micropropagation: a review. *Plant Cell Rep.* 34(5):671-704
- Thomas D (2008) The role of activated charcoal in plant tissue culture. *Biotechnol. Adv.* 26(6):618-631
- van Overbeek J, Conklin ME, and AF Blakeslee (1941). Factors in coconut milk essential for growth and development of very young *Datura* embryos. *Science* 94:350–351.
- Van Staden J, and SE Drewes (1975) Identification of zeatin and zeatin riboside in coconut milk. *Physiol. Plant.* 34:106–109.
- Van Waes JM and PC Debergh (1986) In vitro germination of some Western European orchids. *Physiol. Plant.* 67:253-261
- Van Winkle SC and GS Pullman (2005) Achieving desired plant growth regulator levels in liquid plant tissue culture media that include activated carbon. *Plant Cell Rep.* 24:201-208
- Yam TW and J Arditti (2009) History of orchid propagation: a mirror of the history of biotechnology. *Plant Biotechnol. Rep.* 3:1-56.
- Yong JWH, Ge L, Ng YF, and SN Tan (2009) The Chemical Composition and Biological Properties of Coconut (*Cocos nucifera* L.) Water. *Molecules* 14:5144-5164.

PhytoTech Labs Inc.

Phone: 888-749-8682 or 1-913-341-5343

phytotechlab.com

Procedure	Product No.	Product Description	Comments
Seed Sowing— Epiphytic Orchids	P723	Orchid Seed Sowing Medium w/ Agar	Complete medium with charcoal and gelling agent. Also can be used for terrestrial orchid seed germination.
	K400	Knudson C Orchid Medium	Low salt formulation. Requires the addition of gelling agent.
	V505	Vacin and Went Modified Basal Salt Mixture	Low salt formulation. Requires the addition of vitamins, sucrose, and gelling agent.
	V882	Vacin & Went Orchid Medium	Low salt formulation. Requires the addition of sucrose and gelling agent.
	V891	Vacin & Went Modified Basal Salts	Low salt formulation. Requires the addition of gelling agent.
	V895	Vacin and Went Modified Basal Salt Medium	Low salt formulation. Complete medium. Does not contain charcoal.
Seed Sowing— Terrestrial Orchids	B141	BM-1 Orchid Medium	Complete medium. Does not contain charcoal. Organic nitrogen based medium.
	M551	Malmgren's Modified Terrestrial Orchid Medium	Complete medium. Organic nitrogen based media.
	T849	Terrestrial (<i>Cypripedium</i>) Orchid Medium	Complete medium. Does not contain charcoal. Some species may require the addition of 1-2 mg/L of kinetin for best results. Inorganic nitrogen-based media.
	F522	Fast Terrestrial Orchid Medium	Complete Medium. Does not contain charcoal. Contains both sucrose and fructose.
	T839	Terrestrial (<i>Cypripedium</i>) Orchid Medium	Complete medium. Does not contain charcoal. Formulation without NH ₄ NO ₃ .
Stem Props (<i>Phalaenopsis</i> and other species)	O753	Orchid Multiplication Medium w/Agar	Complete medium.
	P793	Orchid Multiplication Medium	Requires the addition of gelling agent.
	M507	Murashige Cattleya Orchid Multiplication Medium	Best if used at ¼ to ½ strength. May need to be supplemented with 1-2 mg/L of either BA or kinetin.
Clonal Propagation & Multiplication	P793	Orchid Multiplication Medium	Use at ¼ to ½ strength for best results.
	M507	Murashige Cattleya Orchid Multiplication Medium	Best if used at ¼ to ½ strength. May need to be supplemented with 1-2 mg/L of either BA or kinetin.
	K400	Knudson C Orchid Medium	Low salt formulation. Requires the addition of gelling agent.
	V505	Vacin and Went Modified Basal Salt Mixture	Low salt formulation. Requires the addition of vitamins, sucrose, and gelling agent.
	V882	Vacin & Went Orchid Medium	Low salt formulation. Requires the addition of sucrose and gelling agent.
	V891	Vacin & Went Modified Basal Salts	Low salt formulation. Requires the addition of gelling agent.
Replanting	P748	Orchid Maintenance/Replate Medium w/Banana	Complete medium. Works well with <i>Phalaenopsis</i> , <i>Cattleya</i> , <i>Dendrobium</i> , and similar species.
	P785	Orchid Replate Medium	Complete medium. Works well with <i>Cattleya</i> and similar species.
	P668	Orchid Maintenance Medium w/Charcoal	Requires the addition of gelling agent. Should be supplemented with either banana powder or coconut water. Use at ¼ to ½ strength for best results with some species.
	O156	Orchid Maintenance Medium w/Banana and Charcoal	Requires the addition of gelling agent.
	O139	Orchid Maintenance Medium w/out Charcoal	Requires the addition of gelling agent. Should be supplemented with either banana powder or coconut water.
	B142	BM-2 Orchid Medium	Complete medium for terrestrial orchids. May work well with some <i>Paphiopedilum</i> and <i>Phragmipedium</i> species and hybrids. The addition of banana powder, pineapple powder, and/or coconut water may be beneficial.
	M579	Mitra Replate/Maintenance Medium	Complete medium. Contains charcoal. May work well with some <i>Vanda</i> and <i>Dendrobium</i> species and hybrids. The addition of coconut water may be beneficial.
	P656	PhytoTech <i>Phalaenopsis</i> Replate Medium	Complete medium. Contains charcoal. Works well with most <i>Phalaenopsis</i> species and hybrids, and related species and hybrids. The addition of coconut water may be beneficial.

PhytoTech Labs Inc.

Phone: 888-749-8682 or 1-913-341-5343

phytotechlab.com

Product No.	Product Description
A111	AGAR Micropropagation/Plant Tissue Culture Grade Plant Tissue Culture Tested
A296	AGAR (Agar-Agar; Gum Agar) Bacteriological Grade Plant Tissue Culture Tested
A133	AGARGELLAN A blend of agar and Gelrite. Plant Tissue Culture Tested
A1000	AGAR Technical Grade Plant Tissue Culture Tested
B852	BANANA POWDER A mixture of Natural Banana Puree and Maltodextrin. Plant Tissue Culture Tested
B130	BENZYLADENINE SOLUTION (1 mg/mL) (BAP; BA; 6-Benzylaminopurine) Plant Tissue Culture Tested
C184	CASEIN, ENZYMATIC HYDROLYSATE Enzymatic digest of milk Plant Tissue Culture Tested
C195	COCONUT WATER Natural, No Additives Plant Tissue Culture Tested
C325	CHARCOAL, ACTIVATED, ACID WASHED Plant Tissue Culture Tested
G434	GELLAN GUM CultureGel™ type I – Biotech Grade; White to cream free flowing powder; trans: 82%+
G386	D-GLUCOSE, ANHYDROUS Plant Tissue Culture Tested
I364	INDOLE-3-ACETIC ACID SOLUTION (1 mg/mL) (IAA; Heteroauxin) Plant Tissue Culture Tested
I460	INDOLE-3-BUTYRIC ACID SOLUTION (1 mg/mL) (IBA; 4-[3-Indolyl]butyric Acid) Plant Tissue Culture Tested
K424	KEIKI PASTE Lanolin-base Plant Tissue Culture Tested
K483	KINETIN SOLUTION (1 mg/mL) (6-Furfurylaminopurine) Plant Tissue Culture Tested
N605	α-NAPHTHALENEACETIC ACID SOLUTION (1mg/mL) (NAA; 1-Naphthaleneacetic Acid) Plant Tissue Culture Tested
P721	PEPTONE, SOYMEAL Papanic Digest from Soy Plant Tissue Culture Tested
P775	PEPTONE, Type 1, Enzymatic Digest from Meat Plant Tissue Culture Tested

Product No.	Product Description
P780	PEPTONE, GLYSATE From Gelatin Plant Tissue Culture Tested
P862	PINEAPPLE POWDER Dried Pineapple Puree w/Maltodextrin Use at 5-30 g/L Plant Tissue Culture Tested
S391	SUCROSE (α-D-Glucopyranosyl-β-D-fructofuranoside; Saccharose) Plant Tissue Culture Tested
T872	TOMATO POWDER Dried Tomato Puree w/Maltodextrin Plant Tissue Culture Tested
Y892	YEAST EXTRACT Plant Tissue Culture Tested

Product No.	Orchid Kit Description
0799	ORCHID SEED SOWING KIT, EPIPHYTIC ORCHIDS Contains: P723 – Orchid Seed Sowing Medium P748 – Orchid Replate Medium P785 – Orchid Replate Medium C215 – Culture Vessels F951 – Forceps P959 – pH Indicator Strips S963 – Scalpel S971 – Scalpel Blades Instruction Manual
0788	ORCHID SEED SOWING KIT, TERRESTRIAL ORCHIDS Contains: B141 – BM-1 Orchid Seed Sowing Medium B142 – BM-2 Orchid Medium M551 – Malmgren's Modified Terrestrial Orchid Medium T849 – Terrestrial Orchid Medium C215 – Culture Vessels F951 – Forceps P959 – pH Indicator Strips S963 – Scalpel S971 – Scalpel Blades Instruction Manual
0755	ORCHID STEM PROPAGATION KIT Contains: P748 – Orchid Replate Medium B141 – BM-1 Orchid Seed Sowing Medium B142 – BM-2 Orchid Medium O753 – Orchid Multiplication Medium C215 – Culture Containers F951 – Forceps P959 – pH Indicator Strips S963 – Scalpel S971 – Scalpel Blades Instruction Manual

PhytoTech Labs Inc.

Phone: 888-749-8682 or 1-913-341-5343

phytotechlab.com

Product No.	Product Description
A003	SEALING FILM PVC; 3.5 cm W x 150 m L
B939	BEAKERS, GRADUATED, GRIFFIN PMP, AUTOCLAVABLE 2000 mL
B960	BEAKERS, GRADUATED, GRIFFIN PMP, AUTOCLAVABLE 5000 mL
C070	PHYTOCAP™ CLOSURE For use with CultureJar™ G9 Polypropylene Autoclavable
C215	PHYTOCON™-16 CULTURE VESSEL Clear Polypropylene, w/ Lid 4-1/2"D x 2-3/4"H Autoclavable
C597	WIDE-MOUTH CULTURE VESSEL (16 oz) Glass with Polypropylene Lid 3-1/2"D x 3-3/4" H Autoclavable
C607	WIDE-MOUTH CULTURE VESSEL (32 oz) Glass with Polypropylene Lid 3-1/2"D x 6-3/4" H Autoclavable
C1770	CULTUREJAR™ G9, CULTURE VESSEL Glass 2"D x 3-3/4" H Autoclavable
C2118	STERICON™ -8 CULTURE VESSEL Clear PETE, w/ Lid 4"L x 4"H x 3" H γ-irradiated, Sterile, Not Autoclavable

Product No.	Product Description
F979	FLASKS, ERLLENMEYER, 250 mL, WIDE MOUTH Kimax
F980	FLASKS, ERLLENMEYER, 500 mL, WIDE MOUTH Kimax
F985	FLASK, ERLLENMEYER 1000 mL, Wide Mouth
F950	FORCEPS, DRESSING, 6" 1.3 mm tip width
F951	FORCEPS, DRESSING, 8" 3.4 mm tip width
F952	FORCEPS, DRESSING, 10" 3.8 mm tip width
F953	FORCEPS, DRESSING, 12" 4.4 mm tip width
F955	FORCEPS, CURVED, 6" 1.1 mm tip width
F956	FORCEPS, CURVED, 8" 1.3 mm tip width
F957	FORCEPS, BAYONET 8.25" Length (21 cm)
P959	pH INDICATOR STRIPS 0-14 pH Range
S970	SCALPEL BLADE, No. 10 Sterile Carbon Steel; Individually Wrapped
S971	SCALPEL BLADE, No. 11 Sterile Carbon Steel; Individually Wrapped
S963	SCALPEL HANDLE, No. 3 For use with No. 10 & 11 blades 5" Length
S973	SCALPEL HANDLE, No. 3L For use with No. 10 & 11 blades 8" Length

PhytoTech Labs Inc.

Phone: 888-749-8682 or 1-913-341-5343

phytotechlab.com